

# 053

# SPACERS

ØD mm	50	55	60	70
ød mm	30	35	40	50
ØD mm	50	55	60	70
ød inch	1-1/4"	1-3/8"	1-9/16"	1-13/16"
<b>B mm</b>	<b>B Inch</b>			
0.1 - 0.2 - 0.5 - 1.0	.004" - .008" - .020" - .040"			
2.0	.040"			
5.0	3/16"			
10.0	25/64"			
8.1 - 20	5/16" - 3/4"			
20.1 - 30	53/64" - 1-3/16"			
30.1 - 40	1-3/16" - 1-9/16"			
40.1 - 50	1-9/16" - 2"			

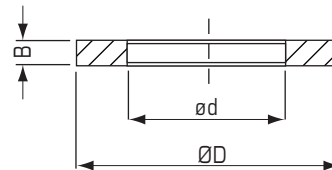

# 057

# BALL BEARING GUIDES

PART NO.	O.D. ØD	I.D. ød	THICKNESS T
W057114-3	3"	1-1/4"	7/8"
W057114-4	4"	1-1/4"	7/8"
W057114-80	80mm	40mm	18mm

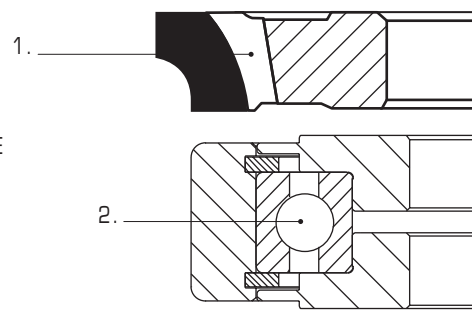
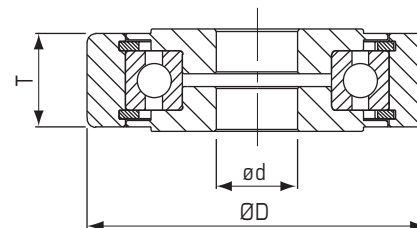

- 1= CUTTER
- 2= BALL BEARING GUIDE

# 035

# SLEEVES

### SPECIAL PRODUCTION

ØD mm	ød mm	ØD INCH	ød INCH			
35	30	1-1/4"	3/4"			
40	30-35	1-13/16"	1-1/4"			
50	30-35-40					
L=mm	2	5	10	15	20	30
L= inch	5/64"	3/16"	3/8"	5/8"	3/4"	1-3/16"

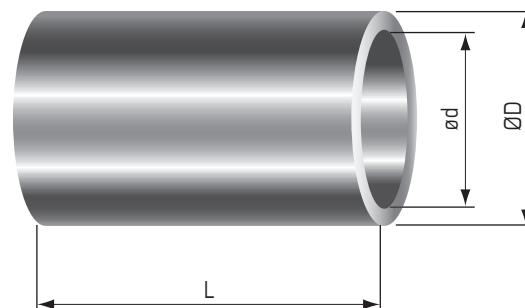

# 054

# FLANGED SLEEVES

PART NO.	O.D. ØD	I.D. ød	LENGTH Lmm
054-3175-1905	1-1/4"	3/4"	20
054-3175-254	1-1/4"	1"	20
054-40-3175	40mm	1-1/4"	20

Other sizes available upon request.

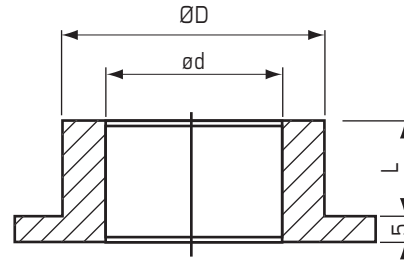

# 058

# BUSHINGS FOR SAW BLADES

PART NO.	O.D. ØD	I.D. ød	THICKNESS T mm
058-114001	1-1/4"	1"	2.1
058-114034	1-1/4"	3/4"	2.1
058-114058	1-1/4"	5/8"	2.1
058-118001	1-1/8"	1"	2.1
058-001034	1"	3/4"	2.1
058-001058	1"	5/8"	2.1
058-020038	20mm	3/8"	2.1
058-020058	20mm	5/8"	2.1
058-022020	22mm	20mm	2.1
058-022034	22mm	3/4"	2.1
058-022058	22mm	5/8"	2.1
058-034058	3/4"	5/8"	2.1
058-030001	30mm	1"	2.1
058-030034	30mm	3/4"	2.1
058-030058	30mm	5/8"	2.1
058-032020	32mm	20mm	2.1
058-040114	40mm	1-1/4"	2.1
058-040138	40mm	1-3/8"	2.1

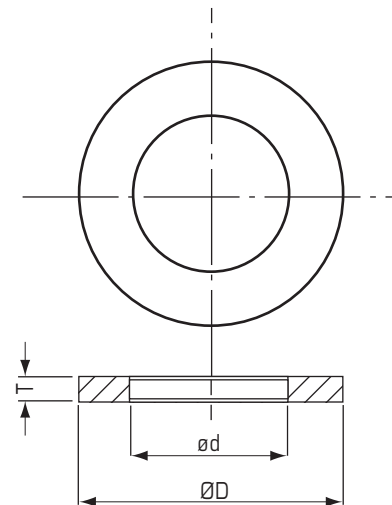

**SPECIAL PRODUCTION**

O.D. ØD	I.D. ød	USABLE LENGTH L1 mm	OVERALL LENGTH L mm	ROTATION
50	1-1/4"	70	90	RH/LH
50	1-1/4"	85	105	RH/LH
50	1-1/2"	85	105	RH/LH
50	40mm	70	90	RH/LH
50	40mm	90	112	RH/LH
60	1-1/4"	85	105	RH/LH
60	1-1/2"	85	105	RH/LH
60	40mm	90	112	RH/LH

Other sizes available.

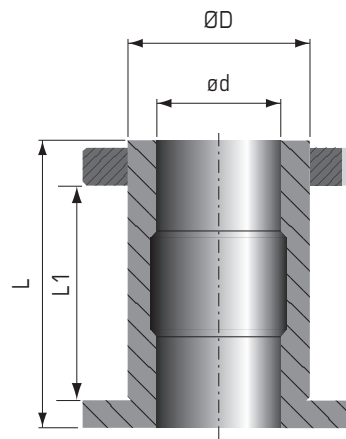

ØD mm	ød mm	ØD INCH	ød INCH
60	30	2-3/8"	5/8" - 1"
80	30	3-1/8"	5/8" - 1"
100	30	4"	5/8" - 1"
125	30	5"	5/8" - 1"
150	30	6"	5/8" - 1"

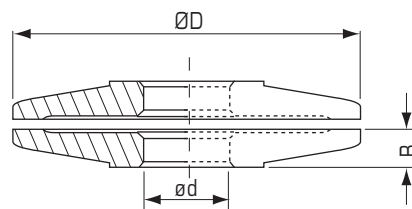

A large grid of 25 columns and 40 rows, intended for handwritten notes.