

**CUTTERS AND CUTTER COMBINATIONS**  
Carbide or Stellite Tipped

PRODUCT CATEGORY	PAGE NO.
ADJUSTABLE GROOVING CUTTERS	B9 - B10
CONVEX RADIUS CUTTERS	B13
CUT-ALL CUTTER SET	B18 - B22
DUAL QUARTER ROUND CUTTERS	B13
EDGEBANDING CUTTERS	B4
ENTRY AND PASSAGE DOOR CUTTER SET	B17
GROOVING CUTTERS	B6 - B7
HALF ROUND CUTTERS	B12
HORIZONTAL PANEL RAISING CUTTERS	B15 - B16
STAGGERED TOOTH JOINTING CUTTERS	B5
LAMELLO GROOVING CUTTERS	B8
PROFILE CUTTERS	B2 - B3
QUARTER ROUND CUTTERS	B12
REVERSIBLE MITRE JOINT CUTTERS	B11
STILE AND RAIL CUTTER SETS	B14
TONGUE AND GROOVE SHAPER CUTTERS	B11

PART NO.	PAGE NO.
1121IC - 11218IC	B6
1121MC - 11221MC	B6
1131IC - 11318IC	B7
1131MC - 11321MC	B7
113B - 113L	B8
1141MC - 1148MC	B9
1151MC - 1152MC	B10
135IC	B11
139IC	B11
1491IC - 1494IC	B12
1501IC - 1504IC	B12
1516IC - 1518IC	B13
154IC	B13
1681IC - 1696IC	B15
177AI - 177BI	B14
178AI - 179CI	B17
1821IC - 1822IC	B18

**MADE ACCORDING TO APPLICATION:**

**STELLITE** (Stellite Tipped)

For softwood and hardwood without glue lines.

**T.C.T.** (Tungsten Carbide-Tipped)

For hardwood, plywood, chipboard, MDF, and other panel materials.

Our cutters are designed to conform with safety regulations and are dynamically balanced.

To determine min. diameter on profiled cutters, the calculation is:

**bore (B) + 60mm (2-3/8") + (2 x profile depth) (P)**

As per table below:

**METRIC SIZES**

BORE B MM	PROFILE DEPTH P MM							
	5	10	15	20	25	30	35	40
30	100	110	120	130	140	150	160	170
35	105	115	125	135	145	155	165	175
40	110	120	130	140	150	160	170	180
50	120	130	140	150	160	170	180	190
60	130	140	150	160	170	180	190	200

**B = Bore Diameter      P = Profile Depth**

**INCH SIZES**

BORE B	PROFILE DEPTH P				
	3/8"	3/4"	1"	1-1/4"	1-1/2"
3/4"	3-7/8"	4-5/8"	5-1/8"	5-5/8"	6-1/8"
1-1/4"	4-3/8"	5-1/8"	5-5/8"	6-1/8"	6-5/8"
1-13/16"	4-7/8"	5-7/16"	5-11/16"	5-15/16"	6-3/16"
2"	5-1/8"	6-1/8"	6-5/8"	7-1/8"	7-5/8"

**B = Bore Diameter      P = Profile Depth**

**WHEN ORDERING SPECIFY:**

1. Type of cutter as numbered.  
For softwood and hardwood without glue lines.
2. Main dimensions in the following order:  
**(diameter) x (cutting width) x (bore) x (# of teeth)**
3. Cutting materials (STELLITE or T.C.T.).
4. RPM of machine and rate of feed.  
Material to be cut, if possible provide sample.
5. Type of cut: against feed direction or with feed direction.

**WHEN ORDERING CUTTERS WITH PROFILES:**

Fully dimensioned sketches, CAD files, or samples of profiles must be supplied. Details of side to table, fence side, and direction of feed must also be given.

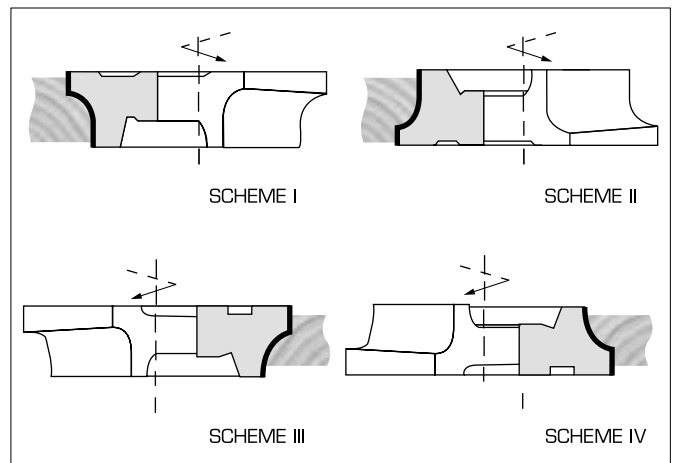

**Direction of Rotation**

Scheme I - II = Counter Clockwise (CCW)  
Scheme III - IV = Counter Clockwise (CCW)

**DESIGN:**

- » With 2, 3, 4, or 6 cutting teeth, straight or with shear angle according to profile

**WHEN ORDERING SPECIFY:**

- » Type of wood or material to be cut
- » Rotation
- » Details of profile to table, fence side
- » RPM of machine
- » Rate of feed
- » Exact sketch of profile
- » Possibly a wood sample or a DXF file
- » Bore diameter
- » Diameter of cutter

Examples of Simple Profiles - PA

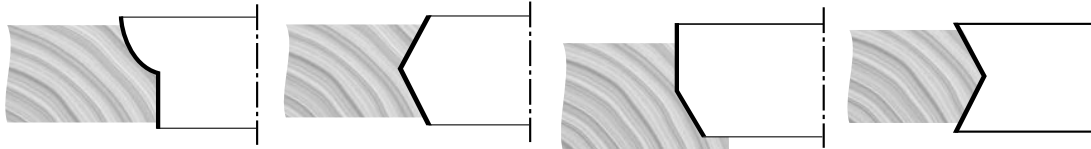
**DESIGN:**

- » With 2, 3, 4, or 6 cutting teeth, straight or with shear angle according to profile

**WHEN ORDERING SPECIFY:**

- » Type of wood or material to be cut
- » Rotation
- » Details of profile to table, fence side
- » RPM of machine
- » Rate of feed
- » Exact sketch of profile
- » Possibly a wood sample or a DXF file
- » Bore diameter
- » Diameter of cutter

Examples of Complex Profiles - PB

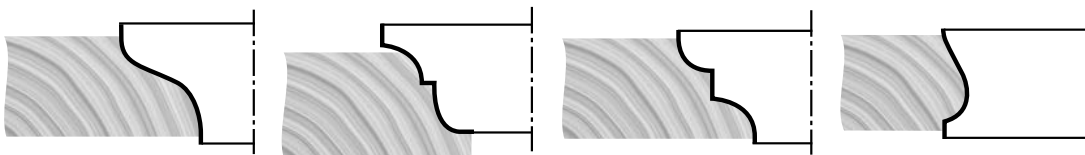

**DESIGN:**

- » With 2, 3, 4, or 6 cutting teeth, straight or with shear angle according to profile

**WHEN ORDERING SPECIFY:**

- » Type of wood or material to be cut
- » Rotation
- » Details of profile to table, fence side
- » RPM of machine
- » Rate of feed
- » Exact sketch of profile
- » Possibly a wood sample or a DXF file
- » Bore diameter
- » Diameter of cutter

Examples of Very Combined Profiles - PC

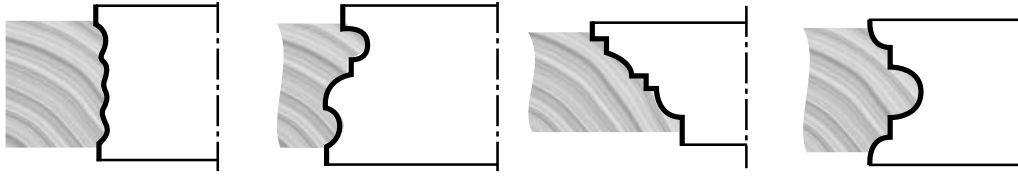
**DESIGN:**

- » With 2, 3, or 4 teeth interlocked for staggered cut and spur action with shearing cut

**WHEN ORDERING SPECIFY:**

- » Type of wood or material to be cut
- » Rotation
- » Details of profile to table, fence side
- » RPM of machine
- » Rate of feed
- » Exact sketch of profile
- » Possibly a wood sample or a DXF file
- » Bore diameter
- » Diameter of cutter

Examples of Combined Profiles - PI

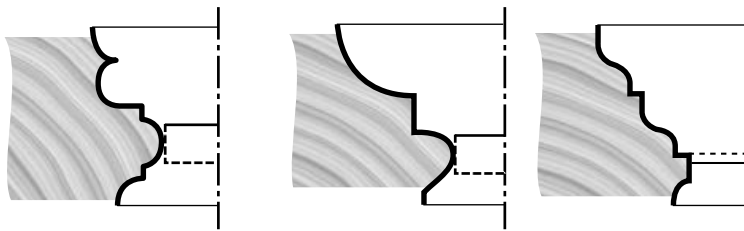

**DESIGN:**

- » High tensile steel body
- » 4 or 6 straight or bevelled teeth
- » Tungsten carbide cutting edges

**APPLICATION:**

- » On edgebanding cutters
- » For flush trimming, chamfering, and profiling of wood veneer and plastic edge bands

**WHEN ORDERING SPECIFY:**

- » Machine
- » If bevelled
- » Cutting edge degrees required

**SPECIAL PRODUCTION**

UNIT OF MEASURE	DIAMETER	KERF	NO. TEETH
INCH	2-3/4" to 4"	5/8" to 1-3/8"	4 or 6
MM	70 to 100	15 to 35	4 or 6

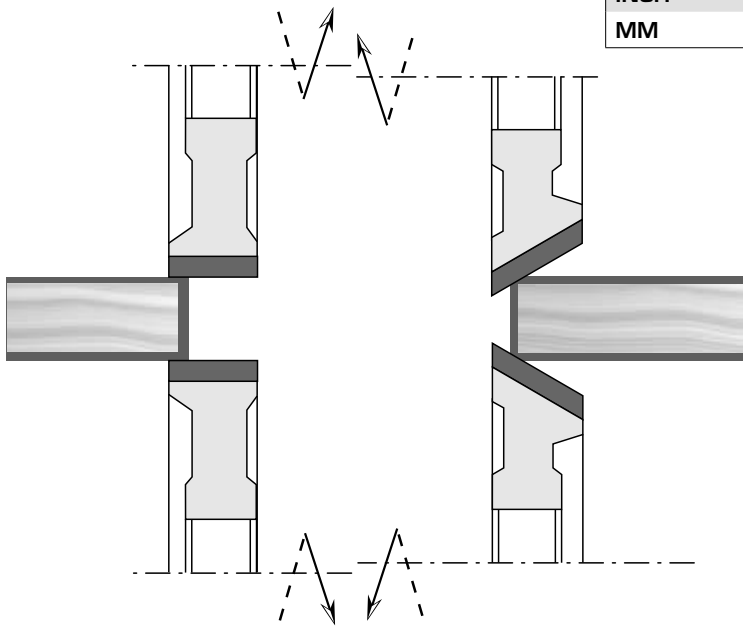



**DESIGN:**

- » High tensile steel body
- » 8 or 12 rows of straight carbide teeth staggered on a spiral progression
- » Tungsten carbide cutting edges

**APPLICATION:**

- » Ideal for "easy chip flow" with fast feeding on solid wood and composite materials
- » Mainly used for roughing-out furniture components
- » On shapers and copying machines

**FOR MACHINES:**

- » Brandt, Egurco, Franke, Homag, Homburg, IDM, IMA, IMEF, Manea, Ocmac, Olympic, Raiman, Salgo, Stefani, and others

**WHEN ORDERING SPECIFY:**

- » Cutter diameter
- » Bore diameter
- » Number of teeth
- » Type of wood to cut
- » Usable length of spindle

**SPECIAL PRODUCTION**

UNIT OF MEASURE	DIAMETER				KERF	NO. TEETH
<b>INCH</b>	3-1/8"	4"	4-3/4"	5-1/2"	2-3/8" to 9"	8 or 12
<b>MM</b>	80	100	120	140	60 to 230	8 or 12

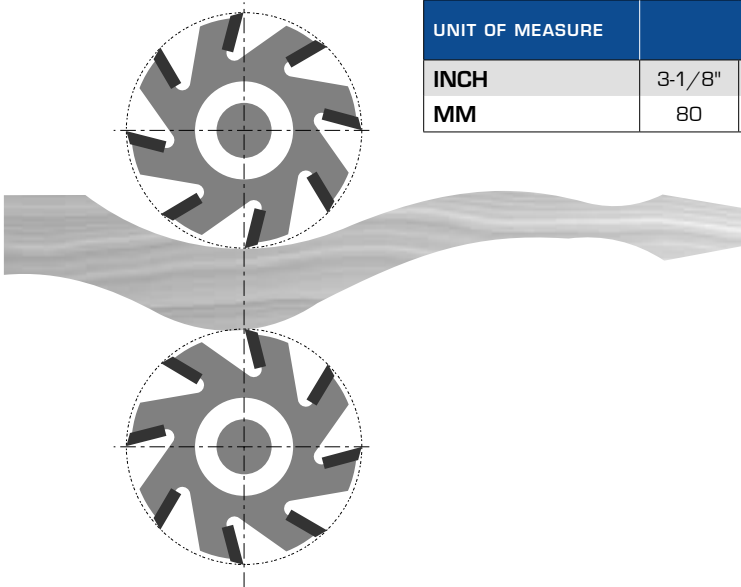

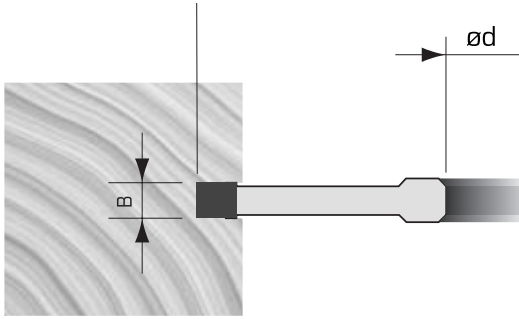

**DESIGN:**

- » High tensile steel body
- » 6 straight teeth
- » If required with alternating teeth or left-right + raker
- » Tungsten carbide cutting edges

**APPLICATION:**

- » To make grooves in solid wood with the grain and in uncoated panels
- » Can be used in laminated materials if cutting with feed

**MACHINES:**

- » On shapers, double-end tenoners, and moulders

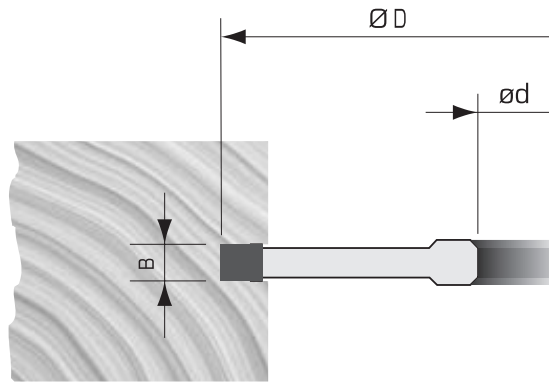
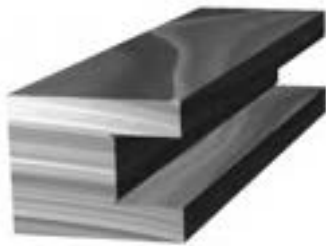
**IMPERIAL**

DIAMETER ØD 4-3/4"	DIAMETER ØD 5-1/2"	DIAMETER ØD 6-1/4"	KERF B	NO. TEETH
PART NO.	PART NO.	PART NO.		
1121IC	1127IC	11213IC	3/16"	6
1122IC	1128IC	11214IC	1/4"	6
1123IC	1129IC	11215IC	5/16"	6
1124IC	11210IC	11216IC	3/8"	6
1125IC	11211IC	11217IC	1/2"	6
1126IC	11212IC	11218IC	5/8"	6

**ød Bore: 1-1/4"**

Bore can be opened or bushed to spindle size of your machine.  
Maximum bore size: 50mm (2")

**Other sizes available upon request**

**METRIC**

DIAMETER ØD 120MM	DIAMETER ØD 140MM	DIAMETER ØD 160MM	KERF B MM	NO. TEETH
PART NO.	PART NO.	PART NO.		
1121MC	1128MC	11215MC	5	6
1122MC	1129MC	11216MC	6	6
1123MC	11210MC	11217MC	8	6
1124MC	11211MC	11218MC	10	6
1125MC	11212MC	11219MC	12	6
1126MC	11213MC	11220MC	14	6
1127MC	11214MC	11221MC	16	6

**ød Bore: 30mm**

Bore can be opened or bushed to spindle size of your machine.  
Maximum bore size: 50mm (2")

**Other sizes available upon request**

**DESIGN:**

- » High tensile steel body
- » With 4 alternating spurs
- » Tungsten carbide cutting edges

**APPLICATION:**

- » For grooving solid wood, plywood, and laminated panels

**MACHINES:**

- » On shapers, double-end tenoners, and moulders

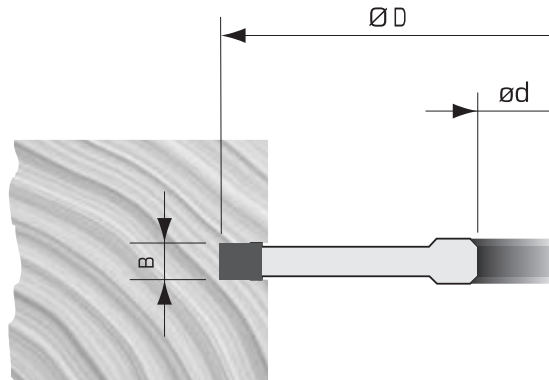
**IMPERIAL**

DIAMETER ØD 4-3/4"	DIAMETER ØD 5-1/2"	DIAMETER ØD 6-1/4"	KERF B	NO. TEETH + SPURS
PART NO.	PART NO.	PART NO.		
1131IC	1137IC	11313IC	3/16"	4+4
1132IC	1138IC	11314IC	1/4"	4+4
1133IC	1139IC	11315IC	5/16"	4+4
1134IC	11310IC	11316IC	3/8"	4+4
1135IC	11311IC	11317IC	1/2"	4+4
1136IC	11312IC	11318IC	5/8"	4+4

**ød Bore: 1-1/4"**

Bore can be opened or bushed to spindle size of your machine.  
Maximum bore size: 50mm (2")

**Other sizes available upon request**

**METRIC**

DIAMETER ØD 120 MM	DIAMETER ØD 140 MM	DIAMETER ØD 160 MM	KERF B MM	NO. TEETH + SPURS
PART NO.	PART NO.	PART NO.		
1131MC	1138MC	11315MC	5	4+4
1132MC	1139MC	11316MC	6	4+4
1133MC	11310MC	11317MC	8	4+4
1134MC	11311MC	11318MC	10	4+4
1135MC	11312MC	11319MC	12	4+4
1136MC	11313MC	11320MC	14	4+4
1137MC	11314MC	11321MC	16	4+4

**ød Bore: 30mm**

Bore can be opened or bushed to spindle size of your machine.  
Maximum bore size: 50mm (2")

**Other sizes available upon request**

**DESIGN:**

- » High tensile steel body
- » With 4 alternating shear angle teeth
- » Tungsten carbide cutting edges

**APPLICATION:**

- » For cutting out defects in solid woods
- » For patch sizes 1-4

**MACHINES:**

- » For use on mini-spot machines

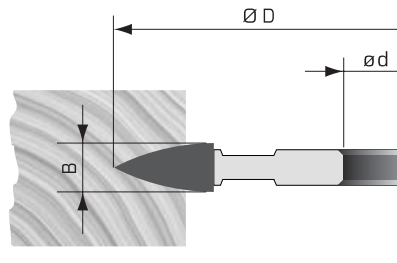

PART NO.	DIAM. Ø D MM	KERF B MM	BORE ø d MM	NO. TEETH	RPM MIN-MAX
113B	100	8	22	4	7600-13400

**DESIGN:**

- » High tensile steel body
- » With 2 teeth and 4 spurs
- » Tungsten carbide cutting edges

**APPLICATION:**

- » For chip free grooving of LAMELLO wood joints
- » For solid woods with and against the grain

**MACHINES:**

- » On LAMELLO and ELU machines for biscuit joints

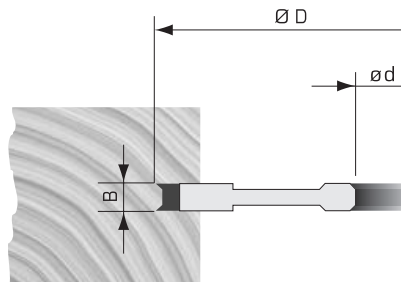

PART NO.	DIAM. Ø MM	KERF B MM	BORE ø d MM	NO. TEETH	NO. SPURS	RPM MIN-MAX
113L	100	3.95	22	2	2+2	7600-13400

**DESIGN:**

- » High tensile steel body
- » Set of cutters with 4 teeth + 4 spurs, each adjustable by a set of spacers
- » Tungsten carbide cutting edges

**APPLICATION:**

- » For chip-free grooving of plywood, chipboard, and solid wood with and across the grain
- » In uncoated and laminated panel materials with feed

**MACHINES:**

- » On shapers, moulders, and double-end tenoners

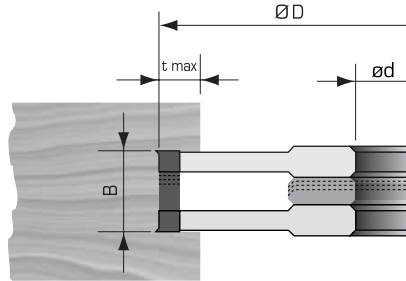

PART NO.	DIAM. ØD	KERF MIN. B	KERF MAX. B	BORE ød	NO. TEETH	NO. SPURS	GROOVE DEPTH T MAX	RPM MIN-MAX
1141MC	140mm 5-1/2"	1.8mm 5/64"	3.4mm 9/64"	31.75mm 1-1/4"	4	4	15mm 19/32"	5500-9500
1142MC	140mm 5-1/2"	2.5mm 3/32"	4.8mm 3/16"	31.75mm 1-1/4"	4	4	15mm 19/32"	5500-9500
1143MC	160mm 6-1/4"	4.0mm 5/32"	7.5mm 19/64"	31.75mm 1-1/4"	4	4	35mm 1-3/8"	5100-9000
1144MC	160mm 6-1/4"	7.5mm 19/64"	14mm 9/16"	31.75mm 1-1/4"	4	4	35mm 1-3/8"	5100-9000
1145MC	160mm 6-1/4"	10mm 13/32"	19mm 3/4"	31.75mm 1-1/4"	4	4	40mm 1-9/16"	4800-8300
1146MC	180mm 7-3/32"	4.0mm 5/32"	7.5mm 19/64"	31.75mm 1-1/4"	4	4	50mm 2"	4200-7400
1147MC	180mm 7-3/32"	7.5mm 19/64"	14mm 9/16"	31.75mm 1-1/4"	4	4	50mm 2"	4200-7400
1148MC	180mm 7-3/32"	10mm 13/32"	19mm 3/4"	31.75mm 1-1/4"	4	4	50mm 2"	4200-7400

Bore can be opened or bushed to spindle size of your machine

Maximum bore size 50mm [2"]

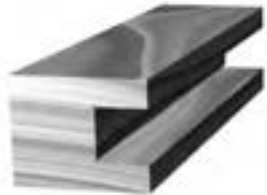

**DESIGN:**

- » High tensile steel body
- » Set of 3 or 4 interlocked cutters adjustable by spacers and shims
- » Outside cutters each with 2 raker teeth and 2 spurs on outside at negative rake
- » Middle cutters with 4 raker teeth
- » Chip limiter for manual feed
- » Cuts grooves sharp and clean, no tear-outs
- » Tungsten carbide cutting edges

**APPLICATION:**

- » For chip-free grooving of plywood, chipboard, and solid wood with and against the grain
- » In uncoated and laminated panel materials with feed

**MACHINES:**

- » On shapers, moulders, and double-end tenoners

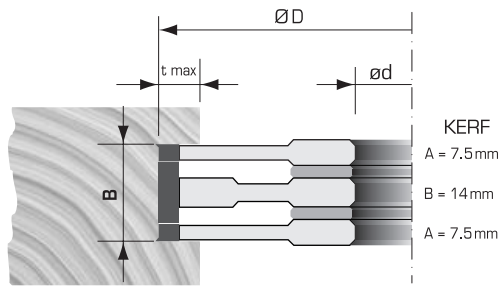

1151MC

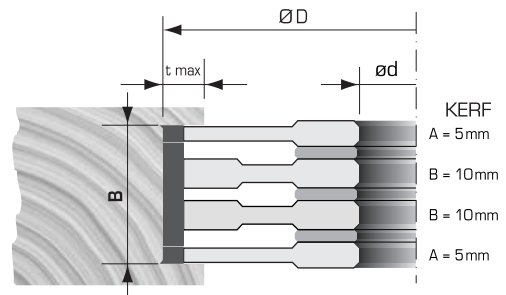

1152MC

PART NO.	DIAM. ØD	KERF MIN. B	KERF MAX. B	BORE ød MM	NO. TEETH	NO. SPURS	GROOVE DEPTH T MAX	RPM MIN-MAX
1151MC	150mm 6"	7.5mm 19/64"	28mm 1-7/64"	31.75mm 1-1/4"	4	4+4	30mm 1-3/16"	5100-8900
1152MC	220mm 8-5/8"	5mm 3/16"	30mm 1-3/16"	31.75mm 1-1/4"	4	4+4	40mm 1-9/16"	3500-6000

Bore can be opened or bushed to spindle size of your machine

Maximum bore size 50mm (2")

**DESIGN:**

- » High tensile steel body
- » Set of 3 cutters (1 groover + 2 cutters)
- » Each with 3 teeth and spacers to obtain profiles
- » Tungsten carbide cutting edges

**APPLICATION:**

- » For producing tongue and groove shapes on plywood and solid wood

**MACHINES:**

- » On shapers

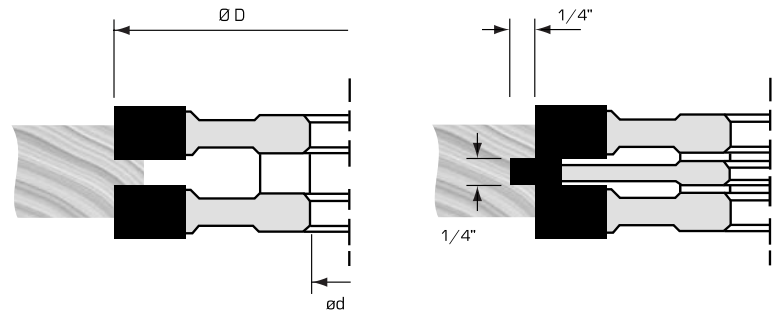

PART NO.	DIAM. ØD	WOOD THICKNESS MIN.	WOOD THICKNESS MAX.	BORE ød	NO. TEETH
139IC	4"	3/4"	1-1/8"	1-1/4"	3+3+3

Bore can be opened or bushed to spindle size of your machine

**DESIGN:**

- » High tensile steel body
- » With 3 straight teeth
- » Tungsten carbide cutting edges

**APPLICATION:**

- » For cutting mitre lock joints in solid wood and panel materials

**MACHINES:**

- » On shapers

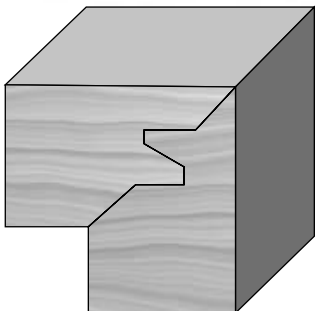
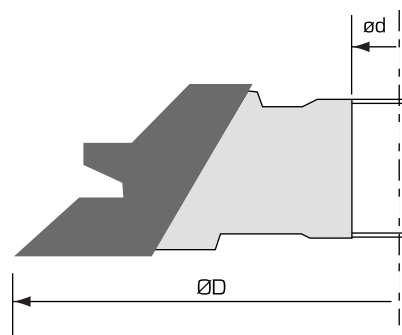

PART NO.	DIAM. ØD	WOOD THICKNESS MIN.	WOOD THICKNESS MAX.	BORE ød	NO. TEETH
135IC	4-3/4"	3/8"	3/4"	1-1/4"	3

Bore can be opened or bushed to spindle size of your machine

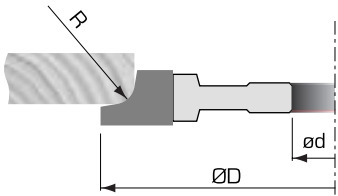
**DESIGN:**

- » High tensile steel body
- » With 3 teeth shear cut for optimum quality of cut
- » Tungsten carbide cutting edges

**APPLICATION:**

- » To cut quarter round shapes in solid wood and panel materials

**MACHINES:**

- » On shapers

**SPECIAL PRODUCTION:**

- » For all other sizes see Cutters Special Profiles "PA" on page B2

PART NO.	DIAM. ØD	RADIUS R	BORE ød	NO. TEETH
14911C	4"	1/4"	1-1/4"	3
14921C	4"	3/8"	1-1/4"	3
14931C	4"	1/2"	1-1/4"	3
14941C	4-3/4"	3/4"	1-1/4"	3

Bore can be opened or bushed to spindle size of your machine

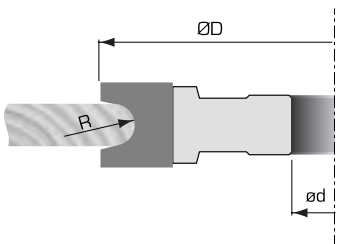
**DESIGN:**

- » High tensile steel body
- » With 3 straight teeth
- » Tungsten carbide cutting edges

**APPLICATION:**

- » To cut half round shapes in solid wood and panel materials

**MACHINES:**

- » On shapers

**SPECIAL PRODUCTION:**

- » For all other sizes see Cutters Special Profiles "PB" on page B2

PART NO.	DIAM. ØD	RADIUS R	PROFILE HEIGHT	BORE ød	NO. TEETH
15011C	4"	1/8"	1/4"	1-1/4"	3
15021C	4"	1/4"	1/2"	1-1/4"	3
15031C	4-1/2"	3/8"	3/4"	1-1/4"	3
15041C	4-1/2"	1/2"	1"	1-1/4"	3

Bore can be opened or bushed to spindle size of your machine





**DESIGN:**

- » High tensile steel body
- » With 4 straight teeth
- » Tungsten carbide cutting edges

**APPLICATION:**

- » For cutting coves in solid wood and panel materials

**MACHINES:**

- » On shapers

**SPECIAL PRODUCTION:**

- » For all other sizes see Cutters Special Profiles "PA" on page B2

PART NO.	DIAM. ØD	RADIUS R	KERF B	BORE ød	NO. TEETH
1516IC	4"	3/8"	3/4"	1-1/4"	4
1518IC	4"	1/2"	1"	1-1/4"	4

Bore can be opened or bushed to spindle size of your machine

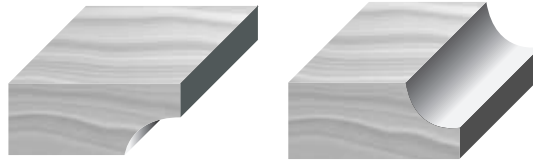
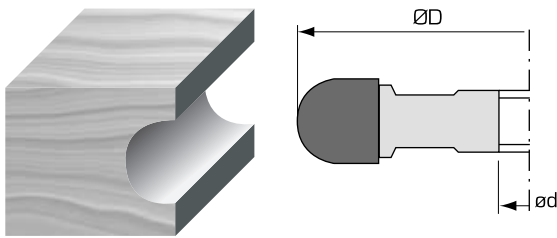

**DESIGN:**

- » High tensile steel body
- » With 3 teeth, straight
- » Tungsten carbide cutting edges

**APPLICATION:**

- » To make 1/4" or 1/2" quarter round shapes in solid wood and panel materials

**MACHINES:**

- » On shapers

**SPECIAL PRODUCTION:**

- » For all other sizes see Cutters Special Profiles "PB" on page B2

PART NO.	DIAM. ØD	RADIUS R1	RADIUS R2	KERF B	BORE ød	NO. TEETH
154IC	4"	1/4"	1/2"	1"	1-1/4"	3

Bore can be opened or bushed to spindle size of your machine

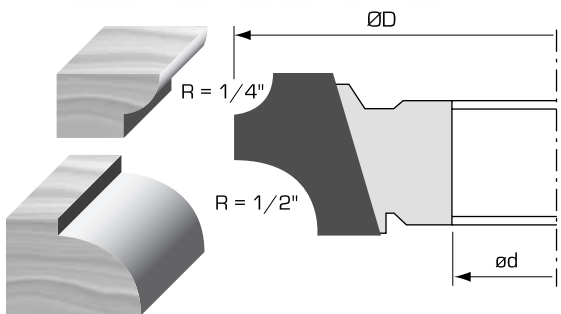

**DESIGN:**

- » High tensile steel body
- » Set of 4 cutters and spacers
- » With 3 teeth
- » Tungsten carbide cutting edges

**APPLICATION:**

- » To cut stile and rail for producing solid wood cabinet doors

**MACHINES:**

- » On shapers

**SPECIAL PRODUCTION:**

- » For all other sizes see Cutters Special Profiles "PA" on page B2

PART NO.	PROFILE	DIAM. ØD	WOOD THICKNESS	BORE ød	NO. TEETH
177AI	A	4"	3/4" to 1"	1-1/4"	3+3
177BI	B	4"	3/4" to 1"	1-1/4"	3+3

Bore can be opened or bushed to spindle size of your machine

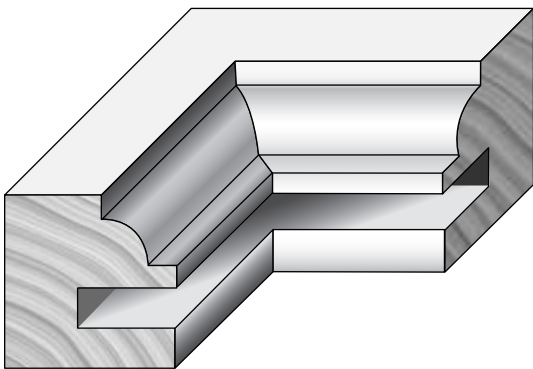
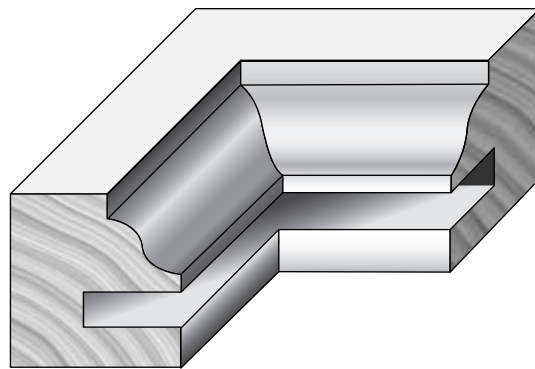
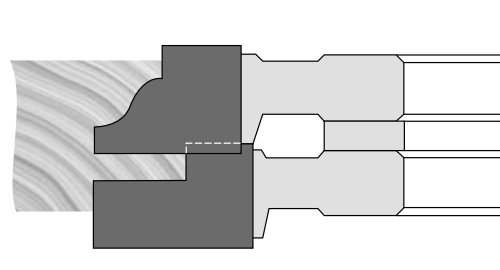
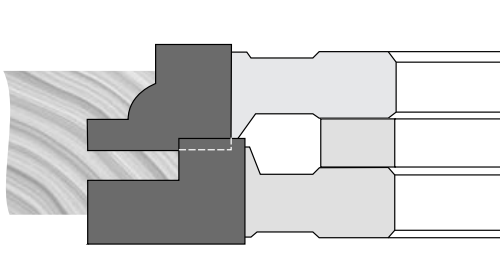
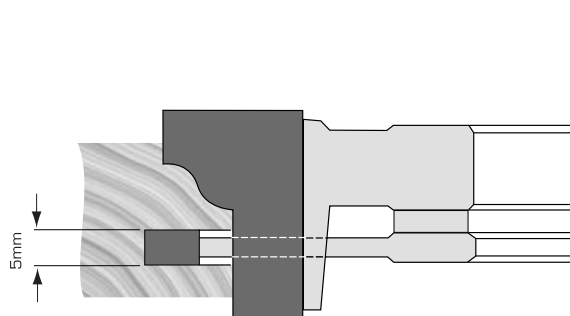
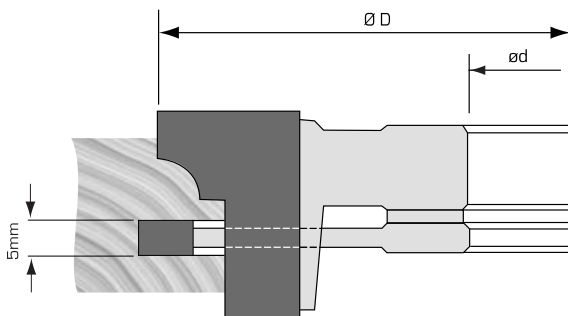
**PROFILE A****BEAD PROFILE****PROFILE B****OGEE PROFILE**

**DESIGN:**

- » High tensile steel body
- » With 3 teeth and shear angle for optimum quality of cut
- » Tungsten carbide cutting edges

**APPLICATION:**

- » For raised panel cutting in solid wood and MDF panels

**MACHINES:**

- » On shapers

PART NO.	PROFILE	DIAM. ØD	KERF B	BORE ød	NO. TEETH
1681IC	Profile No. 1	6"	5/8"	1-1/4"	3
1682IC	Profile No. 2	6"	5/8"	1-1/4"	3
1693IC	Profile No. 3	5-3/4"	5/8"	1-1/4"	3
1694IC	Profile No. 4	5-3/4"	5/8"	1-1/4"	3
1695IC	Profile No. 5	5-3/4"	5/8"	1-1/4"	3
1696IC	Profile No. 6	5-3/4"	5/8"	1-1/4"	3

Bore can be opened or bushed to spindle size of your machine

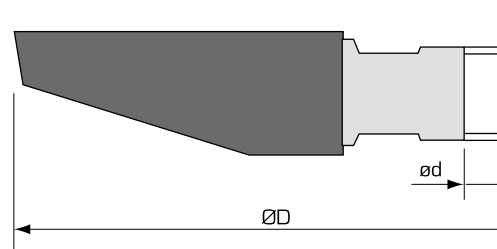
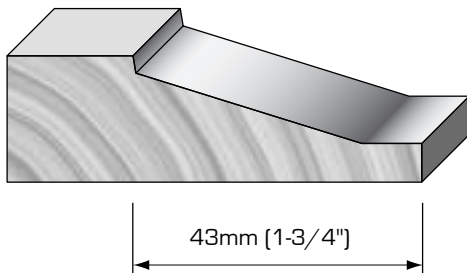
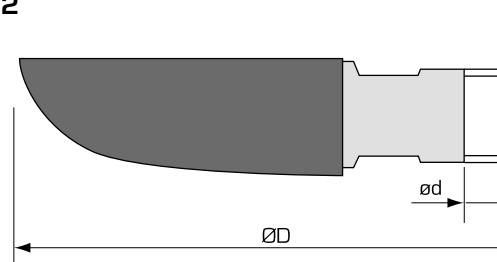
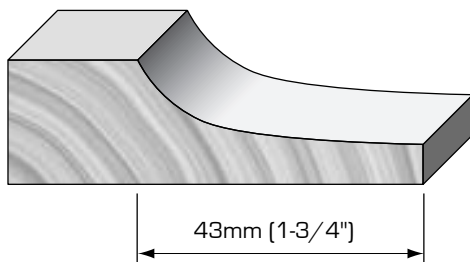
**PROFILE NO. 1****PROFILE NO. 2**

SCALE 1:1

PROFILE NO. 3

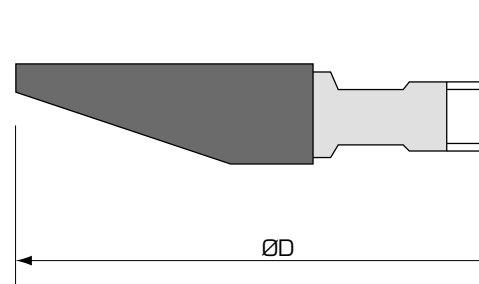
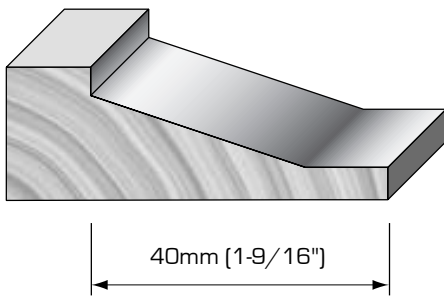

PROFILE NO. 4

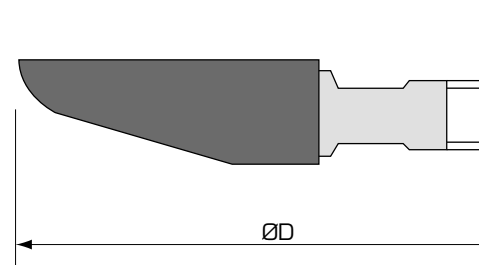
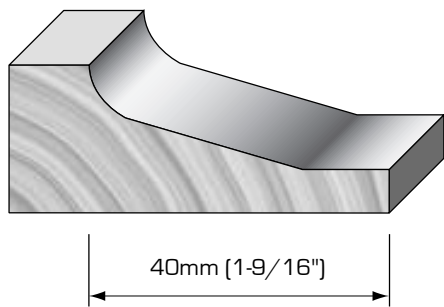

PROFILE NO. 5

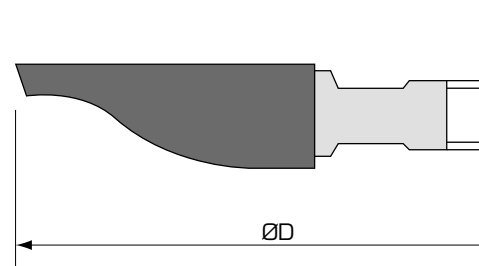
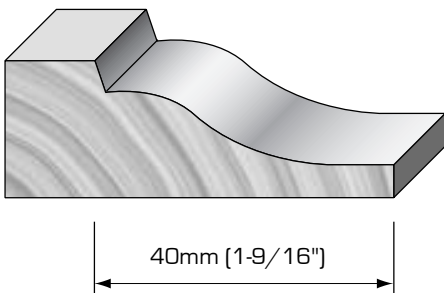

PROFILE NO. 6

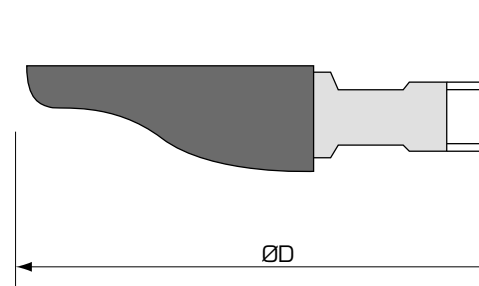
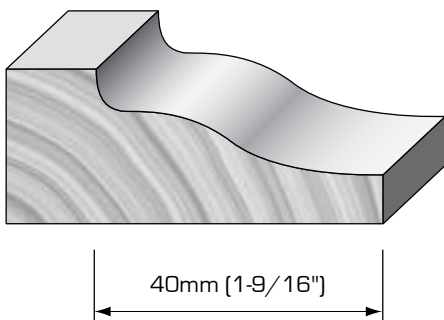

SCALE 1:1

**DESIGN:**

- » High tensile steel body
- » Set of 5 cutters with 3 teeth interlocked and set of spacers
- » Tungsten carbide cutting edges

**APPLICATION:**

- » To cut stile and rail in solid wood for producing entry and passage doors

**MACHINES:**

- » On shapers

**TYPE: 178**

PART NO.	PROFILE	DIAM. ØD	WOOD THICKNESS	TENON	BORE ød	NO. TEETH	RPM MIN-MAX
178AI	A	4"	1-3/8"	1/4"	1-1/4"	3	7500-12500
178BI	B	4"	1-3/8"	1/4"	1-1/4"	3	7500-12500
178CI	C	4"	1-3/8"	1/4"	1-1/4"	3	7500-12500

Bore can be opened or bushed to spindle size of your machine

**TYPE: 179**

PART NO.	PROFILE	DIAM. ØD	WOOD THICKNESS	TENON	BORE ød	NO. TEETH	RPM MIN-MAX
179AI	A	4"	1-3/4"	3/8"	1-1/4"	3	7500-12500
179BI	B	4"	1-3/4"	3/8"	1-1/4"	3	7500-12500
179CI	C	4"	1-3/4"	3/8"	1-1/4"	3	7500-12500

Bore can be opened or bushed to spindle size of your machine

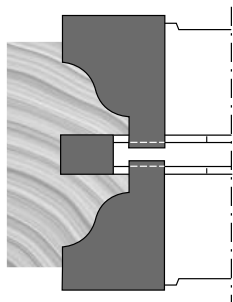
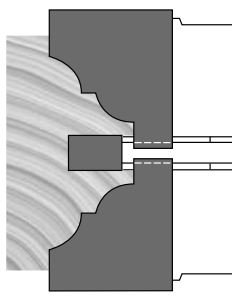
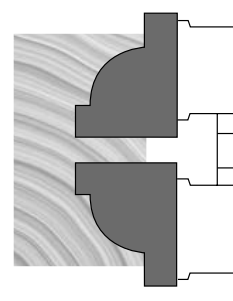
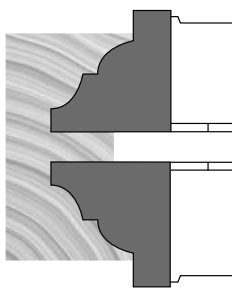
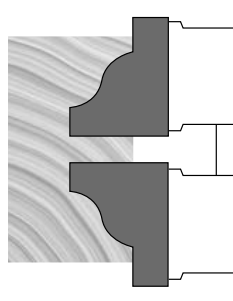
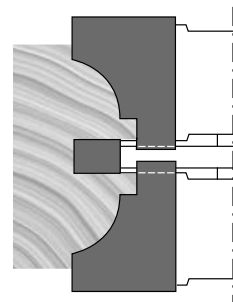
**PROFILE A****PROFILE B****PROFILE C**



**DESIGN:**

- » High tensile steel body
- » Each set consists of 4 cutters with 3 teeth and 3 spacers engraved with No. 1, No. 2, and No. 3
- » Tungsten carbide cutting edges
- » 4 different interlocking joints

**APPLICATION:**

- » To cut all standard moulding profiles and anything else you can think of

**MACHINES:**

- » On shapers

PART NO.	TYPE	DIAM. ØD	BORE ØD	NO. TEETH
1821IC	Small Set	4-1/8"	3/4"	3
1822IC	Large Set	5-1/2"	1-1/4"	3

TOOL. NO. 1

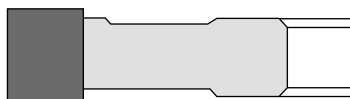

TOOL. NO. 2



TOOL. NO. 3

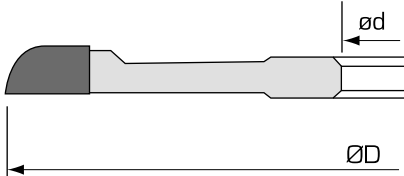

TOOL. NO. 4

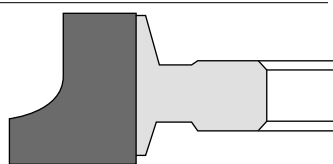

SPACER NO. 5



SPACER NO. 6



SPACER NO. 7



