

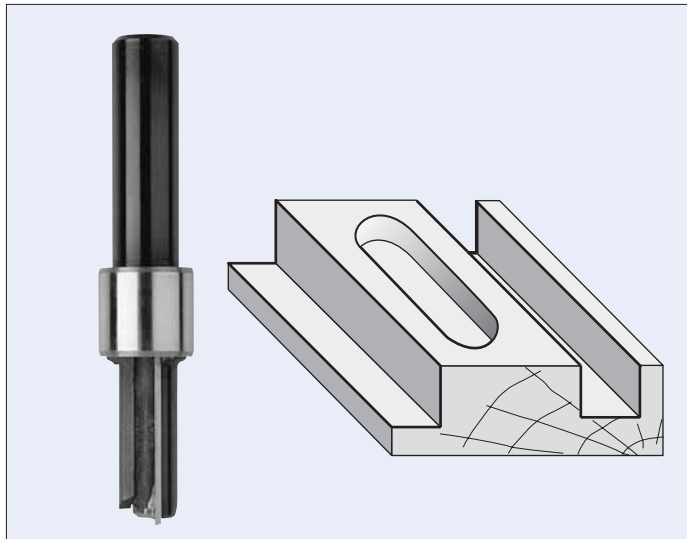

INSERT ROUTER BITS  
& Reversible Inserts

**FD**

**RD2062**
**STRAIGHT ROUTER BITS WITH REVERSIBLE KNIVES**

PART NO.	CUTTING DIAM.	CUTTING LENGTH	SHANK DIAM.	NO. OF FLUTES	OVERALL LENGTH
RD2062	3/8"	1"	1/2"	1	3-1/8"
RD2066	1/2"	1"	1/2"	1	3-3/8"
RD2067	1/2"	1-1/4"	1/2"	1	3-1/2"
RD2067S ▲	1/2"	1-1/4"	1/2"	1	3-1/2"
RD2068 ■	1/2"	1-1/4"	1/2"	1	3-1/2"
RD2069	1/2"	1-1/2"	1/2"	1	4"
RD2069S ▲	1/2"	1-1/2"	1/2"	1	4"
RD2070 ■	1/2"	1-1/2"	1/2"	1	4"
RD2071	1/2"	2"	1/2"	1	4-1/8"
RD2077	5/8"	1-1/4"	1/2"	1	3-1/2"
RD2080 ■	5/8"	2"	5/8"	1	4-3/8"
RD2084	3/4"	1"	1/2"	1	3-3/8"
RD2086 ■	3/4"	1-1/2"	3/4"	1	4"
RD2087 ■	3/4"	2"	3/4"	1	4-3/8"

- ▲ Standard type without reinforcing ring
- With carbide plunge point

**LEFT HAND ROTATION**

PART NO.	CUTTING DIAM.	FLUTE LENGTH	SHANK DIAM.	NO. OF FLUTES	OVERALL LENGTH
RD2067L	1/2"	1-1/4"	1/2"	1	3-1/2"
RD2069L	1/2"	1-1/2"	1/2"	1	4"

**Replacement Parts**  
See page FD3

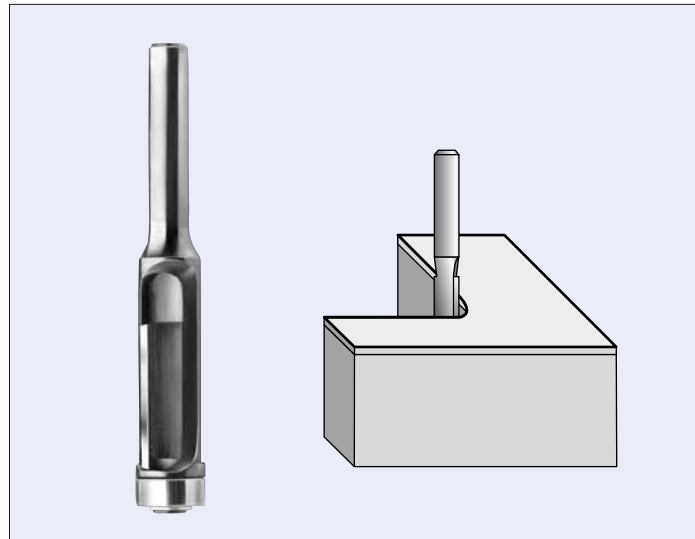
**RD3400**
**FLUSH TRIMMING BITS WITH BALL BEARING GUIDE**

PART NO.	CUTTING DIAM.	CUTTING LENGTH	SHANK DIAM.	NO. OF FLUTES	OVERALL LENGTH
RD3400	3/8"	1"	1/4"	1	2-5/8"
RD3401	3/8"	1/2"	1/4"	1	2-1/8"
RD3402	1/2"	1"	1/4"	1	2-5/8"
RD3403	1/2"	1-1/2"	1/4"	1	2-1/8"
RD3405	1/2"	1"	1/2"	1	2-3/4"
RD3407	1/2"	1-1/2"	1/2"	1	3-5/8"
RD3408	1/2"	2"	1/2"	1	4-1/4"

**Replacement Parts**  
See page FD3

**RD3300**

**BEVEL TRIMMING INSERT BITS  
WITH BALL BEARING GUIDE  
1/4" SHANK DIAM.**

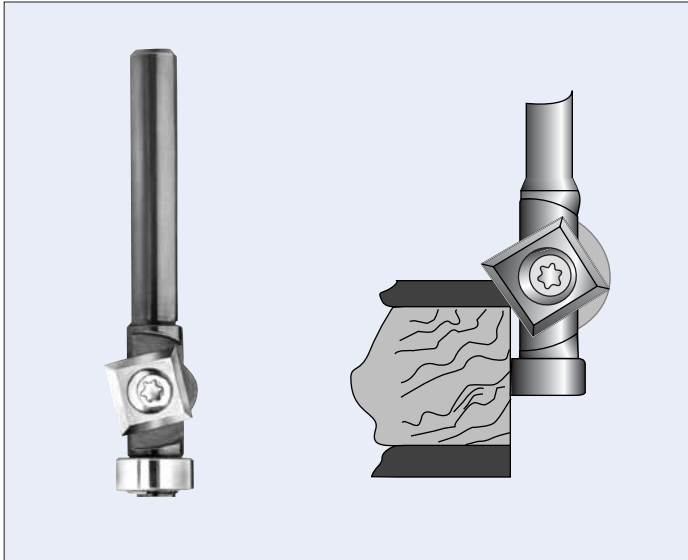

PART NO.	CUTTING DIAM.	CUTTING LENGTH	DEG. BEVEL	NO. OF FLUTES	OVERALL LENGTH
<b>RD3300</b>	3/8"	3/8"	15°	1	2-1/8"
<b>RD3302</b>	3/8"	3/8"	45°	1	2-1/8"

**Replacement Parts**  
See page FD3

**RD2203**

**STAGGERED TOOTH  
INSERT FLUSH TRIMMING WITH  
CENTRE BALL BEARINGS**

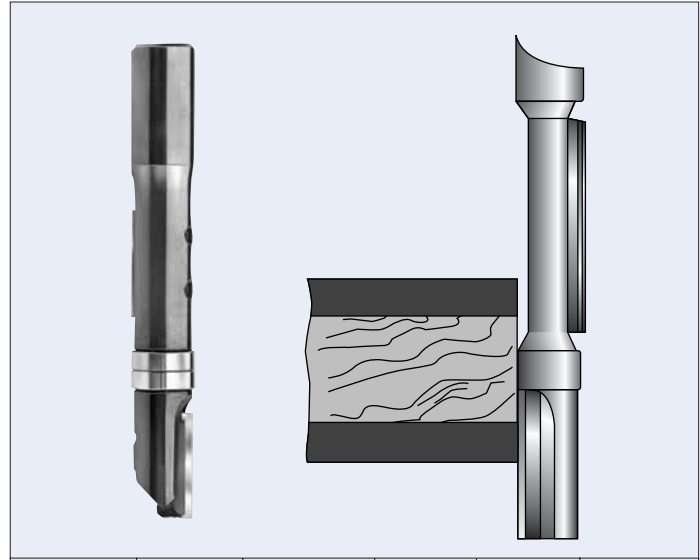

PART NO.	CUTTING DIAM.	CUTTING LENGTH	SHANK DIAM.	NO. OF FLUTES	OVERALL LENGTH
<b>RD2203</b>	1/2"	3/4"+3/4"	1/2"	1+1	3-7/8"
<b>RD2204</b> ■	1/2"	3/4"+3/4"	1/2"	1+1	3-7/8"

■ With carbide plunge point

**Replacement Parts**  
See page FD3

# ROUTER BITS WITH DISPOSABLE KNIVES

## REPLACEMENT PARTS

ROUTER BIT PART NO.	KNIFE PART NO.	WEDGE PART NO.	WEDGE SIZE	BEARING PART NO.	SNAP RING PART NO.	SET SCREW PART NO.	WRENCH PART NO.	LOOSENING JIG PART NO.
RD2062	303511M	W2062	33X5X4.6	-	-	WM303	WT015	W0001
RD2066	303011M	W2066	28X5X4.6	-	-	WM303	WT015	W0001
RD2067	303511M	W2062	33X5X4.6	-	-	WM303	WT015	W0001
RD2067L	303511M	W2062L	33X5X4.6	-	-	WM303	WT015	W0001
RD2068	303511M	W2068	33X5X4.6	-	-	WM303	WT015	W0001
RD2069	304511M	W2069	43X5X4.6	-	-	WM303	WT015	W0001
RD2069L	304511M	W2069L	43X5X4.6	-	-	WM303	WT015	W0001
RD2070	304511M	W2070	43X5X4.6	-	-	WM303	WT015	W0001
RD2071	306011M	W2071	58X5X4.6	-	-	WM303	WT015	W0001
RD2077	303511M	W2077	33X8.5X3.5	-	-	WM306	WT025	-
RD2080	306011M	W2087	58X8.5X3.5	-	-	WM308	WT025	-
RD2084	303011M	W2084	28X8.5X3.5	-	-	WM308	WT025	-
RD2086	304511M	W2086	43X8.5X3.5	-	-	WM308	WT025	-
RD2087	306011M	W2087	58X8.5X3.5	-	-	WM308	WT025	-
RD3400	302511M	W3400	23X4X4.3	BD2	WC050	WM303	WT015	-
RD3401	301211M	W3401	11X4X4.3	BD2	WC050	WM303	WT015	W0001
RD3402	302511M	W3400	23X4X4.3	BD3	WC060	WM303	WT015	W0001
RD3403	304011M	W3403	38X4X4.3	BD3	WC060	WM303	WT015	W0001
RD3405	302511M	W3400	23X4X4.3	BD3	WC060	WM303	WT015	W0001
RD3407	304011M	W3403	38X4X4.3	BD3	WC060	WM303	WT015	W0001
RD3408	305011M	W3408	48X4X4.3	BD3	WC060	WM303	WT015	W0001
RD3300	300911M	-	-	BD2	WC050	WM306	W400401	-
RD3302	300911M	-	-	BD2	WC050	WM306	W400401	-
RD2203	302011M	UPPER						
		W2200	19X4X4.3	BD4	-	WM303	WT015	W0001
		LOWER						
		W2203	18X5X4.6					
RD2204	302011M	UPPER						
		W2200	19X4X4.3	BD4	-	WM303	WT015	W0001
		LOWER						
		W2204	18X5X4.6					

SPARE KNIVES C4 MICRO GRAIN MIRROR FINISH			
PART NO.	LENGTH mm	WIDTH mm	THICKNESS mm
300911M	9	9	1.5
301211M	12	5.5	1.1
301511M	15	5.5	1.1
302011M	20	5.5	1.1
302511M	25	5.5	1.1
303011M	30	5.5	1.1
303511M	35	5.5	1.1
304011M	40	5.5	1.1
304511M	45	5.5	1.1
305011M	50	5.5	1.1
306011M	60	5.5	1.1

SPARE KNIVES STANDARD FINISH			
PART NO.	LENGTH mm	WIDTH mm	THICKNESS mm
303011S	30	5.5	1.1
303511S	35	5.5	1.1
304011S	40	5.5	1.1
304511S	45	5.5	1.1
305011S	50	5.5	1.1
306011S	60	5.5	1.1

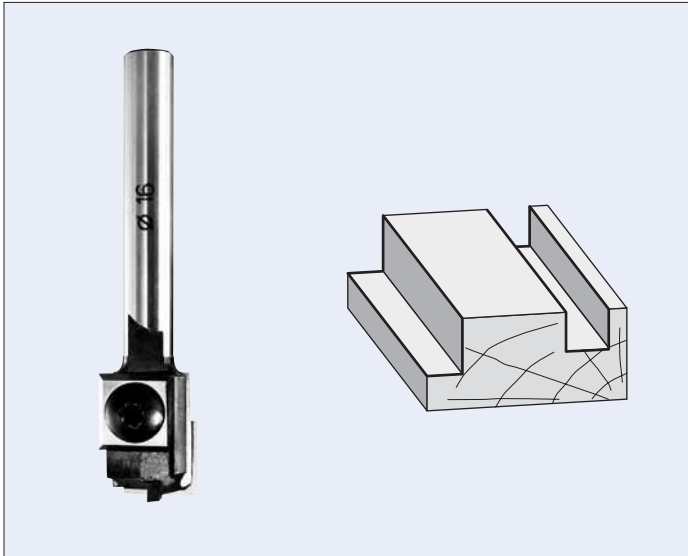
**D1A**
**STAGGERED TOOTH BITS  
ONE + ONE FLUTE WITH PLUNGE POINT**

PART NO.	CUTTING DIAM.	CUTTING LENGTH	SHANK DIAM.	OVERALL LENGTH
D1A15A	15mm	20mm	1/4"	2"
D1A16A	16mm	20mm	1/4"	2"
D1A18A	18mm	20mm	1/4"	2"
D1A20A	20mm	20mm	1/4"	2"
D1A22A	22mm	20mm	1/4"	2"

**Replacement Parts**

Spare Knife 301200      Screw D1V

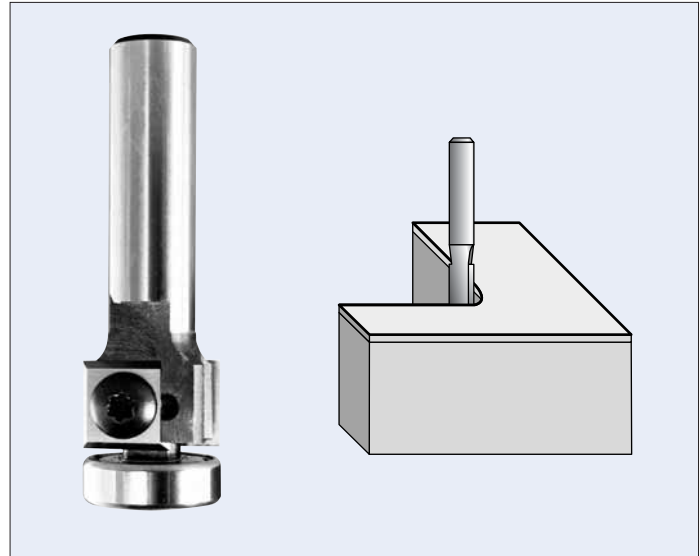
**D1C**
**FLUSH TRIM BITS  
WITH BALL BEARING GUIDE TWO FLUTES**

PART NO.	CUTTING DIAM.	CUTTING LENGTH	SHANK DIAM.	OVERALL LENGTH
D1C	19mm	12mm	6mm	55mm
D1CA	19mm	12mm	1/4"	2-3/16"

**Replacement Parts**

 Spare Knife 301200  
Screw for Knife D1V

 Ball Bearing B3-6  
Screw for Bearing D1V5

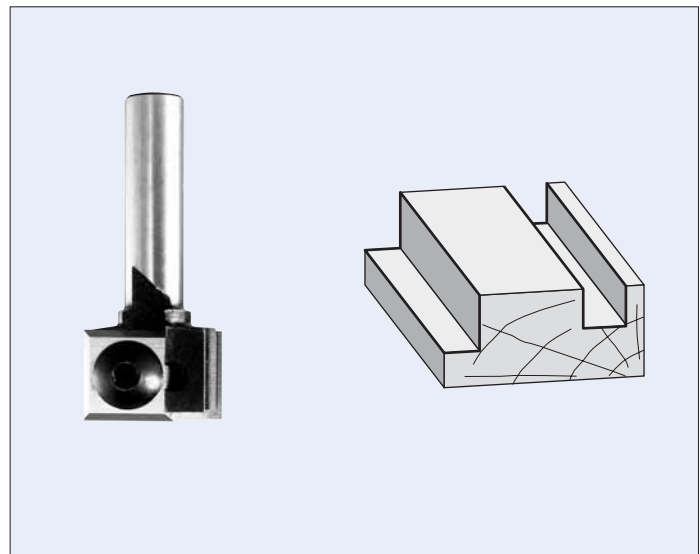
**D1E**
**STRAIGHT ROUTER BITS  
TWO FLUTES**

PART NO.	CUTTING DIAM.	CUTTING LENGTH	SHANK DIAM.	OVERALL LENGTH
D1E	19mm	12mm	6mm	45mm
D1EA	19mm	12mm	1/4"	1-3/4"

**Replacement Parts**

Spare Knife 301200

Screw D1V

**D1B** BEVEL TRIM BITS  
TWO FLUTES

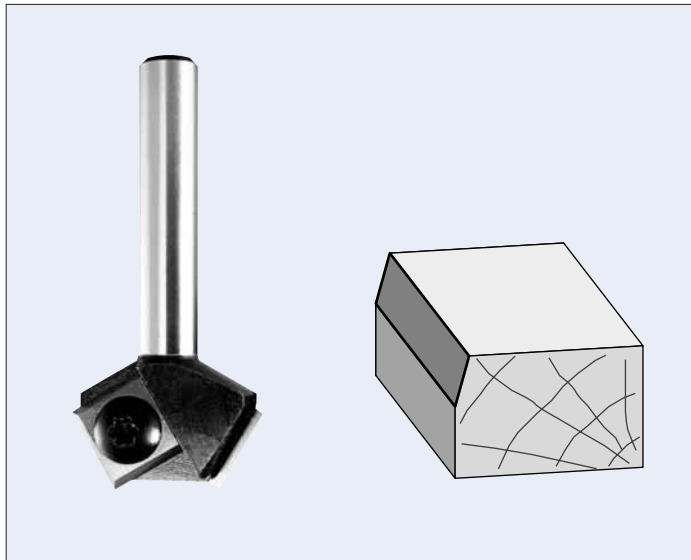

PART NO.	CUTTING DIAM.	CUTTING LENGTH	SHANK DIAM.	DEGREE OF CUT	OVERALL LENGTH
D1B22	24mm	12mm	6mm	22°	45mm
D1B22A	24mm	12mm	1/4"	22°	1-3/4"
D1B30	26mm	12mm	6mm	30°	45mm
D1B30A	26mm	12mm	1/4"	30°	1-3/4"
D1B45	29mm	12mm	6mm	45°	45mm
D1B45A	29mm	12mm	1/4"	45°	1-3/4"

**Replacement Parts**  
Spare Knife 301200      Screw D1V

**D1D** BEVEL TRIM BITS  
WITH BALL BEARING GUIDE TWO FLUTES

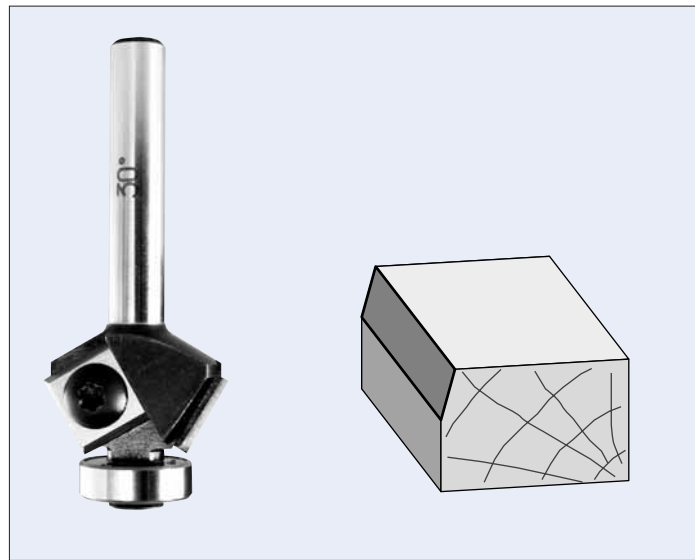

PART NO.	CUTTING DIAM.	CUTTING LENGTH	SHANK DIAM.	DEGREE OF CUT	OVERALL LENGTH
D1D22	24mm	12mm	6mm	22°	55mm
D1D22A	24mm	12mm	1/4"	22°	2-3/16"
D1D30	26mm	12mm	6mm	30°	55mm
D1D30A	26mm	12mm	1/4"	30°	2-3/16"
D1D45	29mm	12mm	6mm	45°	55mm
D1D45A	29mm	12mm	1/4"	45°	2-3/16"

**Replacement Parts**  
Spare Knife 301200      Ball Bearing B3-4  
Screw for knife D1V      Screw for bearing D1V5

**D1A:E** REPLACEMENT PARTS

